

## Twenty-seventh Annual Columbus State Invitational Mathematics Tournament

Sponsored by  
The Columbus State University  
Department of Mathematics  
March 3, 2001

\*\*\*\*\*

The Columbus State University Mathematics faculty welcome you to this year's tournament and to our campus. We wish you success on this test and in your studies of mathematics.

### Instructions

This is a 90-minute, 50-problem, multiple choice examination. There are five possible responses to each question. You should select the one "best" answer for each problem. In some instances this may be the closest approximation rather than an exact answer. You may mark on the test booklet and on the paper provided to you. If you need more paper or an extra pencil, let one of the monitors know. When you are sure of an answer, circle the choice you have made on the test booklet. After you have worked all of the problems that you can work, carefully transfer your answers to the score sheet. Darken completely the blank corresponding to the letter of your response to each question. Mark your answer boldly with a No. 2 pencil. If you must change an answer, completely erase your first choice and then record the new answer. Incomplete erasures and multiple marks for any question will be scored as an incorrect response. The examination will be scored on the basis of +12 for each correct answer, -3 for each incorrect selection, and 0 for each omitted item. Each student will be given an initial score of +200.

Pre-selected problems will be used as tie-breakers for individual awards. These problems, designated with an asterisk (\*), in order of consideration are: 35, 38, 46, 47, and 50.

Throughout the exam,  $AB$  will denote the line segment from point  $A$  to point  $B$  and  $\overline{AB}$  will denote the length of  $AB$ . Pre-drawn geometric figures are not necessarily drawn to scale.

Review and check your score sheet carefully. ***Your student identification number and your school number must be encoded correctly on your score sheet.***

When you complete your test, bring your pencil, scratch paper and answer sheet to the test monitor. You may leave the room after you have handed in your answer sheet. Please leave quietly so as not to disturb the other contestants. Please do not congregate outside the doors by the testing area. You may keep your copy of the test. Your sponsor will have a copy of the answers.

Do not open your test until instructed to do so

1. *A multiple of eleven I be  
not odd, but even, you see.  
My digits a pair,  
when multiplied there,  
make a cube and a square  
out of me. Who am I?*
- (a) 66      (b) 88      (c) 44      (d) 22      (e) 33
2. It takes 1230 numerical characters (digits) to number the pages of a book. How many pages does the book contain?
- (a) 446      (b) 447      (c) 350      (d) 347      (e) 441
3. What number is twice the product of its two digits?
- (a) 20      (b) 11      (c) 36      (d) 24      (e) 52
4. There is an old riddle about a snail at the bottom of a 21-foot well. If he climbs up 4 feet each day and slips back 1 foot each night starting on an early morning Sunday, what is the first day of the week on which he is going to be out of the well?
- (a) Friday                      (b) Saturday                      (c) Sunday  
(d) Monday                      (e) Thursday
5. Solve the equation  $\frac{7}{2x+1} - \frac{8x}{2x-1} + 4 = 0$ .
- (a)  $x = \frac{6}{11}$                       (b)  $x = \frac{11}{6}$                       (c)  $x = -\frac{11}{6}$   
(d)  $x = -\frac{6}{11}$                       (e)  $x = \frac{2}{3}$

6. In three years, Chad will be three times my present age and I will be half as old as he. How old am I now?

- (a) 5            (b) 7            (c) 6            (d) 8            (e) 10

7. Find the sum of all solutions of the equation  $\sqrt{15 - 2x} = x$ .

- (a) 3            (b) -3            (c) 2            (d) -2            (e) 5

8. There are six baseball teams in a tournament. Each team plays each of the other teams twice. How many games are played altogether?

- (a) 28            (b) 38            (c) 30            (d) 40            (e) 22

9. Determine a value of  $b$  for which the equation  $3x^2 + bx + 12 = 0$  has exactly one solution.

- (a) -15            (b) 0            (c) 17            (d) -7            (e) 12

10. How many single matches are needed to determine a winner if 32 participants enter a single-elimination tennis tournament (one loss eliminates a participant)?

- (a) 16            (b) 30            (c) 31            (d) 15            (e) 10

11. Calculate the product of the slope and the  $y$  intercept of the line with equation  $3x + 2y = 8$ .

- (a) -9            (b) -36            (c) -16            (d) -24            (e) -6

12. Paula and Ricardo are serving cupcakes at a school party. If they arrange the cupcakes in groups of 2, 3, 4, 5 or 6, they always have exactly one cupcake left over. What is the smallest number of cupcakes they could have?
- (a) 26      (b) 61      (c) 36      (d) 41      (e) 31
13. Suppose that you have just accepted a job paying \$8 per hour. You are told that after a two-month probationary period, your hourly wage will be increased to \$9 per hour. What percent raise will you receive after the two-month period?
- (a) 12.5%                      (b) 11.1%                      (c) 1.25%  
(d) 1.11%                      (e) 12
14. Determine how many zeros are the end of  $40!$ .
- (a) 8      (b) 7      (c) 10      (d) 9      (e) 11
15. Given that the sum of three consecutive integers is 804, determine the smallest of these integers.
- (a) 267      (b) 257      (c) 277      (d) 287      (e) 187
16. How many prime numbers less than 100 can be written using the digits 1, 2, 3, 4, or 5, if repeating a digit is not allowed (e.g. 11 is not included) ?
- (a) 8      (b) 7      (c) 10      (d) 25      (e) 9

17. Suppose that you have been offered two jobs selling school supplies. One company offers a straight commission of 6% of your sales. The other company offers \$300 per week plus 3% of sales. For which sales level,  $x$ , will the weekly income from the straight commission job exceed the pay from the other job?

(a)  $x > \$25,000$                       (b)  $x > \$2,500$                       (c)  $x < \$30,000$

(d)  $x > \$10,000$                       (e)  $x < \$7,500$

18. Determine the largest three-digit prime all of whose digits are prime. Compute the sum of its digits.

(a) 14                      (b) 17                      (c) 19                      (d) 15                      (e) 13

19. George made enough money by selling candy bars at 15 cents each to buy several cans of pop at 48 cents each. If he had no money left over what is the smallest number of candy bars he could have sold?

(a) 18                      (b) 20                      (c) 21                      (d) 16                      (e) 15

20. What is the area of the region below?

(a) 30                      (b) 16                      (c) 15                      (d) 20                      (e) 14

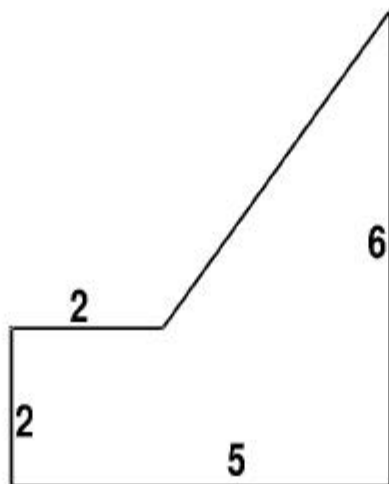

21. All adjacent sides of the decagon shown below meet at right angles. What is its perimeter?

- (a) 22      (b) 32      (c) 44      (d) 50      (e) 34

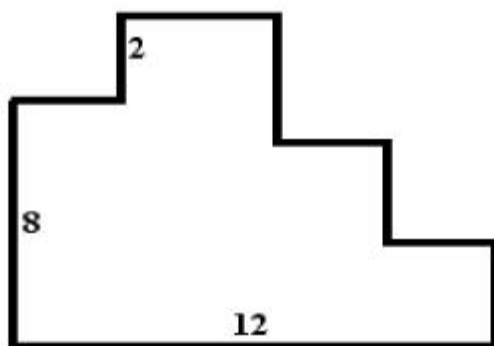

22. Let  $p > 0$ . Find the difference between the larger root and the smaller root of the quadratic equation in  $x$

$$x^2 - px + \frac{p^2 - 1}{4} = 0.$$

- (a) 0      (b) 1      (c) 2      (d)  $p$       (e)  $p + 1$

23. The equation  $x - \frac{7}{x-3} = 3 - \frac{7}{x-3}$  has how many real solutions?

- (a) 4      (b) 2      (c) 0  
(d) 3      (e) 1

24. Evaluate the expression  $\sqrt{0.4444444\dots}$

- (a) 0.222222...      (b) 0.202020...      (c) 0.606060...  
(d) 0.666666...      (e) 0.404040...

25. Suppose that six consecutive integers are written on a blackboard. After one of the numbers has been erased, the sum of the remaining five numbers is 2001. What is the number that was erased?

- (a) 405      (b) 454      (c) 478      (d) 412      (e) 402

26. Suppose that  $f(x) = \frac{x+3}{x-1}$  for  $x \neq 1$ . Find a function  $g(x)$  for which  $g(f(x)) = x$  for all real numbers  $x$  such that  $x \neq 1$ .

- (a) There is no such function  $g$       (b)  $g(x) = \frac{x-1}{x+3}$       (c)  $g(x) = \frac{x-3}{x+1}$

- (d)  $g(x) = \frac{x+3}{x-1}$       (e) None of the above

27. Using the numbers 9, 8, 7, 6, 5, and 4 once each, find the smallest possible positive difference.

- (a) 47      (b) 30      (c) 25      (d) 65      (e) 53

—					

28. What is the remainder of the division of  $111^{2001}$  by 7?

- (a) 3      (b) 6      (c) 5      (d) 2      (e) 1

29. The mean of two numbers is 16 and the mean of their reciprocals is  $\frac{1}{15}$ . Calculate the absolute value of the difference of the two numbers.
- (a) 6      (b) 8      (c) 5      (d) 10      (e) 3
30. Rolling three six sided dice, what is the probability of throwing three numbers which represent the side lengths of a right triangle?
- (a)  $\frac{1}{3}$       (b)  $\frac{1}{36}$       (c)  $\frac{1}{6}$       (d)  $\frac{1}{216}$       (e)  $\frac{1}{5}$
31. The radii of the sprocket assemblies and the wheel of the bicycle in the figure below are 5 inches, 3 inches, and 15 inches, respectively. If a cyclist is pedaling at a rate of 2 revolutions per second, find the speed of the bicycle in miles per hour ( $1 \text{ ft} = 12 \text{ in}$ ,  $1 \text{ mile} = 5280 \text{ ft}$ ) within three decimal places.
- (a) 26.180      (b) 24.324      (c) 17.850      (d) 16.521      (e) 30.334

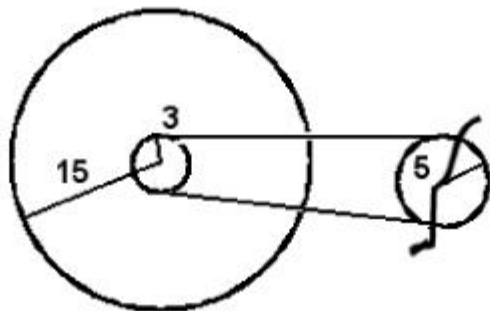

32. If  $A$ ,  $B$  and  $C$  are constants such that the following equality

$$\frac{A}{x-1} + \frac{B}{x-2} + \frac{C}{x-3} = \frac{2}{(x-1)(x-2)(x-3)}$$

holds true for every real number  $x$  except 1, 2 and 3, determine  $A + B + C$ .

- (a) 0      (b) -1      (c) 2      (d) 3      (e) 1



33. How many line segments have both of their endpoints located at the vertices of a given cube?

- (a) 12      (b) 26      (c) 24      (d) 28      (e) 56

34. For two real numbers  $a$  and  $b$ , define an operation “ $*$ ” by  $a * b = a^2b - ab$ . Evaluate the expression  $(x + 1) * x - x * (x + 1)$ .

- (a) 0                      (b)  $2(x^2 + x)$                       (c)  $x^2 + x$   
(d)  $-2(x^2 + x)$                       (e) None of these

35. \* A rectangle with perimeter 176 is divided into five congruent rectangles as shown in the diagram below. What is the perimeter of one of the five congruent rectangles?

- (a) 76      (b) 35.2      (c) 86      (d) 87      (e) 80

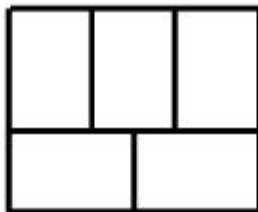

36. The sum of the digits in a two-digit number is 12. If the digits are reversed, the new number is 18 greater than the original number. What is the sum of these two numbers?

- (a) 120      (b) 144      (c) 108      (d) 96      (e) 132

37. It is given that one root of the quadratic equation (in  $x$ )

$$2x^2 + bx + c = 0,$$

with  $b$  and  $c$  real numbers, is  $3 + 2i$  ( $i = \sqrt{-1}$ ). Find the value of  $c$ .

- (a) undetermined                      (b) 26                                      (c) 5  
(d) 6    (e) 13

38. \* Define the sequence of real numbers  $\{x_n\}$  as follows. Let  $x_1 = \sqrt{2}$  and for  $n \geq 2$ , let  $x_n$  be defined recursively by the formula  $x_n = (\sqrt{2})^{x_{n-1}}$ . For instance,  $x_2 = \sqrt{2}^{\sqrt{2}}$ ,  $x_3 = \sqrt{2}^{(\sqrt{2}^{\sqrt{2}})}$ , and so on. Estimate the interval in which  $x_{2001}$  is situated?

- (a)  $2 < x_{2001} < 3$                       (b)  $3 < x_{2001} < 4$                       (c)  $4 < x_{2001} < 5$   
(d)  $1 < x_{2001} < 2$                       (e)  $5 < x_{2001} < 6$

39. The quadrilateral ABCD has side lengths  $\overline{AB} = 11.7$  in,  $\overline{BC} = 4.4$  in,  $\overline{CD} = 10$  in,  $\overline{DA} = 7.5$  in and  $\overline{AC} = 12.5$  in. (Notice that the triangles ABC and ADC are right triangles.) Use the Law of Cosines in the triangle BCD and the Sum Formula (i.e.  $\cos(\alpha + \beta) = \cos(\alpha)\cos(\beta) - \sin(\alpha)\sin(\beta)$ ) to find the length  $\overline{BD}$ .

- (a) 12.5 in    (b) 13 in    (c) 11 in    (d) 10 in    (e) 12 in

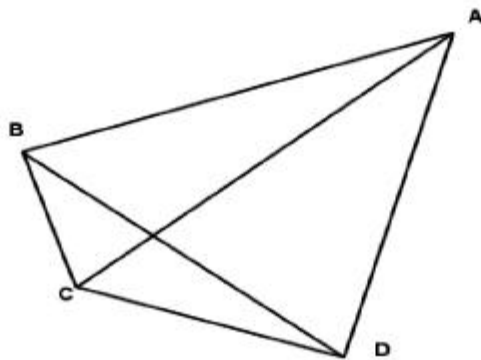



45. In the figure below suppose  $\angle ABC = 90^\circ$ ,  $\angle CDB = 45^\circ$ ,  $\angle CAB = 30^\circ$ , and  $\overline{AD} = 4$ . Find  $\overline{BC}$ .

- (a)  $2\sqrt{3} + 1$    (b)  $2\sqrt{3} - 1$    (c)  $2\sqrt{3} + 2$    (d)  $\sqrt{2}$    (e)  $2\sqrt{3}$

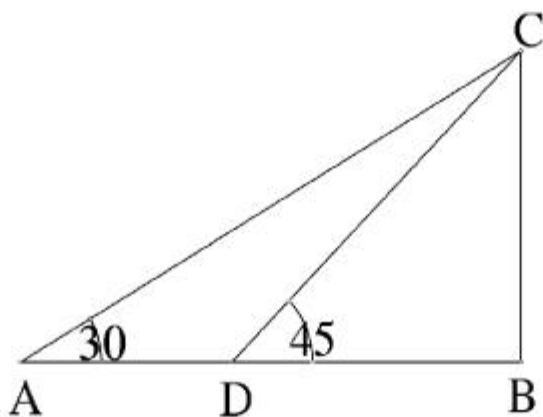

46. \* How many real numbers are solutions of the equation  $x^{1000} + |x| = 10$ ?

- (a) 0   (b) 2   (c) 1000   (d) 3   (e) 500

47. \* *The inequality*

$$\sqrt{n+1} - \sqrt{n} < \frac{1}{\sqrt{4n+1}} < \sqrt{n} - \sqrt{n-1}$$

*holds true for all positive integers  $n$ .*

Using this inequality, one can say that the sum

$$S = \frac{1}{\sqrt{5}} + \frac{1}{\sqrt{9}} + \frac{1}{\sqrt{13}} + \frac{1}{\sqrt{17}} + \dots + \frac{1}{\sqrt{1997}} + \frac{1}{\sqrt{2001}}$$

is in which of the following intervals?

- (a)  $30 < S < 32$    (b)  $40 < S < 42$    (c)  $20 < S < 21$   
 (d)  $21 < S < 24$    (e)  $31 < S < 32$

48. Place the whole numbers 1 through 9 in the circles in the accompanying triangle so that the sum of the numbers on each side is 17. What is the sum of the numbers placed in the vertices of the triangle?

- (a) 7      (b) 8      (c) 9      (d) 6      (e) 10

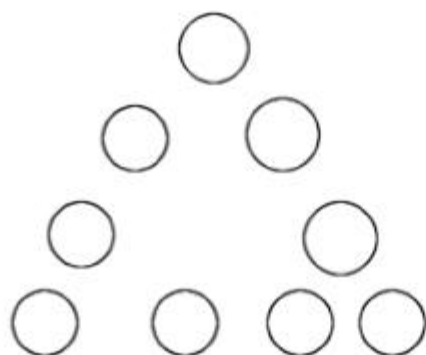

49. Two rectangles intersect in a sixty degree angle as depicted below. Suppose that the horizontal rectangle measures two inches by twenty inches, while the other rectangle measures one inch by fifteen inches. Find the area of the parallelogram formed by the intersection of these two rectangles.

- (a)  $3 - \frac{4\sqrt{3}}{3}$       (b)  $4 - \frac{2\sqrt{3}}{3}$       (c)  $\frac{4}{5}\sqrt{3}$   
 (d)  $\frac{4\sqrt{3}}{3}$       (e)  $\frac{3\sqrt{3}}{4}$

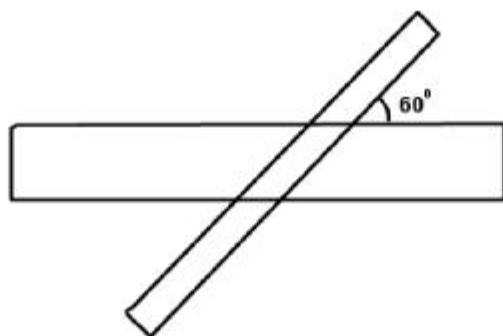

50. \* *Refer to the figure below.* A circle is inscribed in an equilateral triangle with sides measuring 1 inch. Three line segments are drawn, each one tangent to the circle such that they cut off equilateral triangles at each corner of the original triangle. Circles are then inscribed in each of the corner triangles and then tangent lines are drawn and 9 equilateral triangles are formed. If this process is continued indefinitely, what is the sum of the areas (in square inches) of all the circles which appear in this construction?

(a)  $\frac{\pi}{6}$

(b)  $\frac{\pi}{8}$

(c)  $\frac{\pi}{5}$

(d)  $\frac{\pi}{9}$

(e)  $\frac{\pi}{3}$

